

Model #  
**EP50K**



36-volt electric chain drive pusher.

- **Capacity:** 50,000 lbs
- **Platform Dim:** 34.4" x 79.88" x 56" w/o 5th Wheel Arm
- **Weight:** 1250 lbs.

### Features:

- 2000 lb. Differential / Transaxle
- 36V - (3) 150Amp Batteries
- 5000 lbs Hydraulic Actuator Lift Kit
- 2:1 Gear Reduction with Chain Driven Tires
- Safety Stop Switch
- (3) Solid Fork Truck Drive Tires
- 0-3 mph Fwd/Rev Variable Speed Grip
- Adjustable Acceleration/Braking
- 15A Sealed Battery Charger
- Battery Discharge Indicator
- Heavy Duty Steel Frame
- Pintle Hitch
- 1 Year Limited Warranty

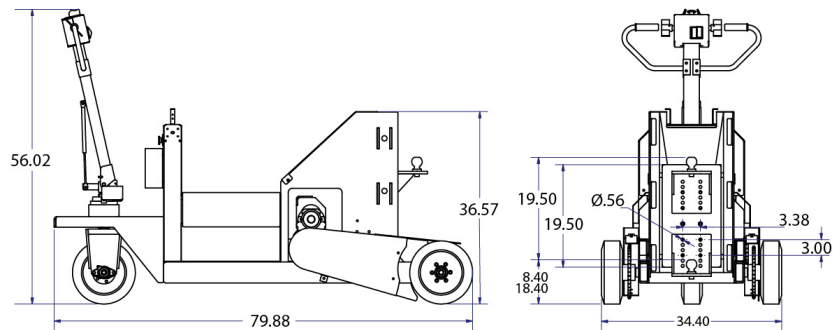

### Optional Upgrades

- Flashing Light and Pole
- Safety Horn
- Maintenance Free Batteries
- Sealed AGM Batteries (110 amp/hr)
- Trojan Batteries - (6) 150Amp Batteries
- 9 Tooth gears (1.77 mph)
- (2) 16" Dual Solid Drive Tires
- Ball Hitch and Steel Mounting Bracket
- Fully Enclosed Chain Guards

### Carts designed for EP50K



\* All Dimensions are in inches

- **Capacity:** 50,000 lbs
- **Frame:** Structural steel channel
- **Deck:** .25" Plate Steel
- **Deck Height:** 24.375
- **Size Options:** 60x60, 60x96, 60x120, 60x144
- **Wheel type:** (4) S-MDD-124SYT-4SL swivel casters
- **Load Retention:** (4) forged steel lashing rings; 15,000 SWL