



Model #
EP10K

Design for heavier loads using a “U” channel to grab the end rail of the cart.

- **Capacity:** 10,000 lbs
- **Platform Dim:** 26.4” x 42” x 41.1” w/o 5th Wheel Arm
- **Weight:** 950 lbs.

Features:

- 1500 lb. Differential/Transaxle
- 36V - (3) 80Amp Batteries
- Adjustable Steel Attachment
- Safety Stop Switch and Guard Kit
- Electric Lift Kit
- 5th Wheel Arm (Includes centering coupler and lever kit)
- Non-Marking Tires
- 250 lbs Weight: For increased traction
- Adjustable Acceleration/Braking
- 0-3 mph FWD/REV Variable Speed Grip
- Battery Discharge Indicator
- Welded Sheet Steel Frame
- 750 lbs. Added for More Traction
- 1 Year Limited Warranty

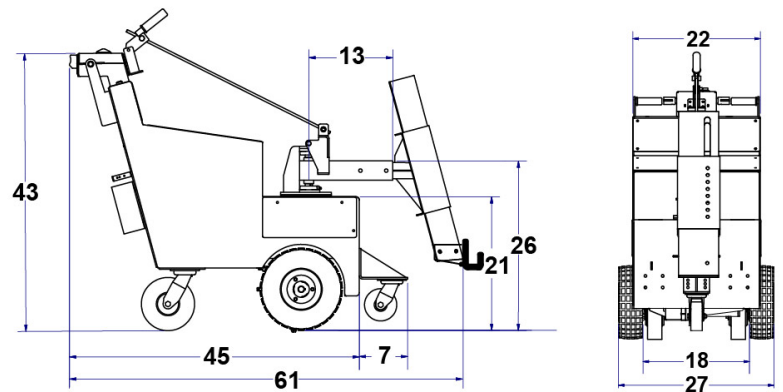

Carts designed for EP10K

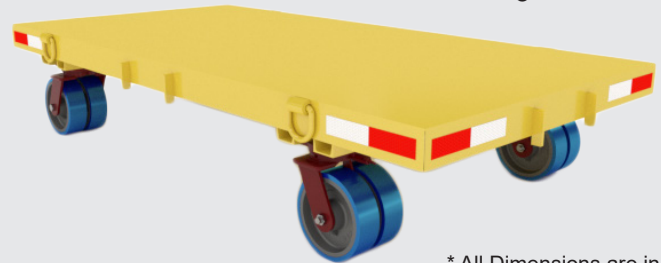

* All Dimensions are in inches

- **Capacity:** 10,000 lbs
- **Frame:** 4” Structural steel channel
- **Deck:** 7ga. Sheet Steel
- **Deck Height:** 18.125
- **Size Options:** 48x96, 48x108, 60x120, 60x144
- **Wheel type:** (4) S-EHD2-13SPB-4SL swivel casters
- **Load Retention:** (4) forged steel lashing rings; 9,000 SWL

Optional Upgrades

- Flashing Light and Pole
- Safety Horn
- Maintenance-free Batteries (set of 3)
- Power and Brake Motor Upgrade
- Foam Filled Tires (Set)
- Internal 15A or 30A Charger Upgrades