



Model #  
**EP100K**

48-volt electric chain drive pusher. Designed for the most demanding pushing or pulling jobs.

- **Capacity:** 100,000 lbs
- **Platform Dim:** 46.3" x 79.88" x 56" w/o 5th Wheel Arm
- **Weight:** 1250 lbs.

## Features:

- 3000 lb. Differential / Transaxle
- 48V - (4) 150Amp Batteries
- 5000 lbs Hydraulic Actuator Lift Kit
- 2:1 Gear Reduction with Chain Driven Tires
- (6) Solid Fork Truck Drive Tires
- Safety Stop Switch
- 0-3 mph Fwd/Rev Variable Speed Grip
- Adjustable Acceleration/Braking
- 15A Sealed Battery Charger
- Battery Discharge Indicator
- Heavy Duty Steel Frame
- Pintle Hitch
- 1 Year Limited Warranty

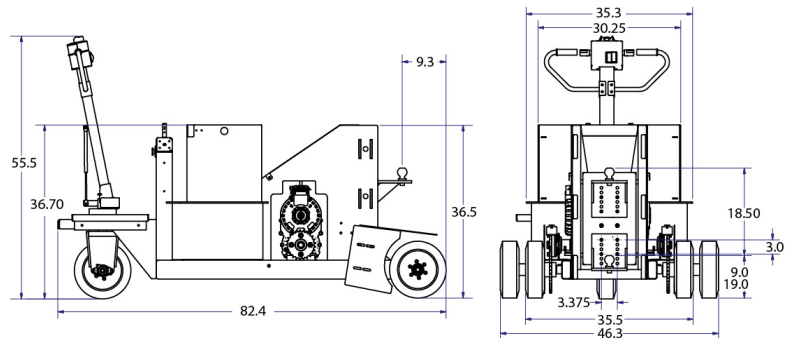

## Optional Upgrades

- Flashing Light and Pole
- Safety Horn
- Maintenance Free Batteries
- Sealed AGM Batteries (110 amp/hr)
- Trojan Batteries - (8) 150Amp Batteries
- Ball Hitch and Steel Mounting Bracket
- Fully Enclosed Chain Guards
- Tooth gears (1.77 mph)

## Carts designed for EP100K



\* All Dimensions are in inches

- **Capacity:** 100,000 lbs
- **Frame:** Structural steel WF beam
- **Deck:** .5" Plate Steel
- **Deck Height:** 34
- **Size Options:** 60x96, 60x120, 60x144, 60x192"
- **Wheel type:** (4) S-UMD2-165NYB-4SL swivel casters
- **Load Retention:** (8) forged steel lashing rings; 15,586 SWL